

GENERAL CHARACTERISTICS

These level switches (**ML series**) constitute a simple, reliable and economic solution for the control of the level in all those applications where the space and simplicity of assembly are mandatory for the user.

- Small size.
- Economical and reliable.
- Executions in Polypropylene and PVDF
- Operating ambient temperature -30 / +55 °C - 90% RH.
- Easy and quick installation.
- Degree of protection IP65.



S1.FML.GC-Z

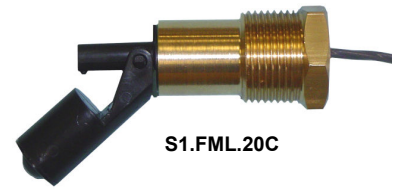

S1.FML.20C



S1.PML.GC-Z

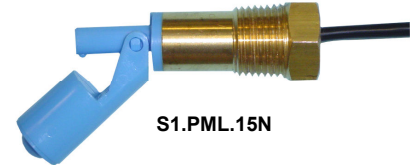

S1.PML.15N

TECHNICAL DATA

Tab.1

Type	Material		Float S.G.	Pressure Bar	Temperature °C
PML	Polypropylene	Blue	0,6	3	90
FML	PVDF	Black	0,75	6	130

PROCESS CONNECTIONS

Tab.2

Assembly from inside the tank	Assembly from outside the tank and available threads		
16K Standard body thread M16 x 1,5 Installation see Tab.4	GC- Viton standard compression gasket. Installation see Tab.4		15 1/2" C - N
			20 3/4" C - N

Male thread

C	N
Conical UNI 7/1	Conical NPT
15 - 20	

Available materials

O	S	P	F
Brass	AISI-316	Polypropylene	PVDF
15 - 20		16K	

Gasket

Viton	Z	Silicon	W
Standard		On request	
16K - GC			

ELECTRICAL CONTACT

Tab.3

TYPE		POWER		VOLTAGE		CURRENT	
		VA	W	AC	DC	AC	DC
3D	SPST	70	50	300	350	0,5	0,7
7D	SPDT	20	20	150	150	0,5	0,5

Wiring

C1	1,5m cable	C	Cable length on request
C2	3m cable	FST	Male faston 2 x 0,8

DIMENSIONS

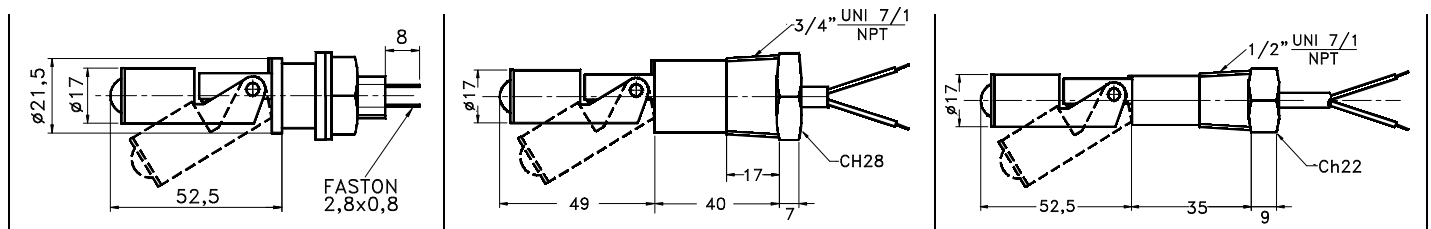

OPERATION

A normally open reed contact is sealed in the body of the instrument, in the float there is housed a permanent magnet. At the moment in which the thrust of the liquid, lifting up the float, approaches the magnet to the electrical contact occurs the closure of the contact itself.

Rotating the instrument through 180 degrees around its own axis, the float will be, in the absence of level, against the abutment point and the contact will be closed.

The thrust of the liquid, in this case, depart the float from the contact causing it to open.

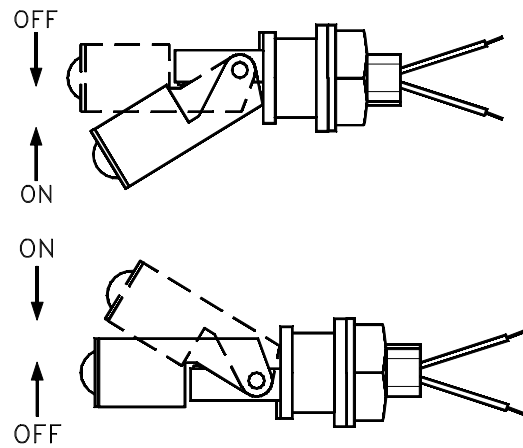

ASSEMBLY AND INSTALLATION

Tab.4

Assembly from inside the tank 16K

- Drill a hole \varnothing 16.5 mm in the tank.
- Unscrew the fixing nut and remove the washer and the expansion gasket.
- Insert the flat sealing gasket.
- Insert the level switch into the hole (\varnothing 16.5 mm) of the tank.
- Screw the fixing nut up to compress the flat gasket, inside the tank, taking the position indicator downward to have the contact N.O. or upward to have the contact N.C.

Assembly from outside the tank GC-

- Drill a hole \varnothing 22 mm in the tank.
- Insert the level switch into the hole until the compression gasket stops.
- Screw the fixing nut so that the gasket begins to expand inside the tank.
- Place the position indicator downward to have the N.O. contact or upward to have the N.C. contact.
- Tighten the nut in order to complete the expansion of the gasket and thus obtain the tightness of the system.

Caution: Verify that the holes for housing the instrument, in the tank, are carefully deburred, in order to avoid damage to the seal and to obtain a perfect hydraulic seal.

INSTALLING FROM OUTSIDE GC-

INSTALLING FROM INSIDE 16K

INSTALLING FROM OUTSIDE 15-20

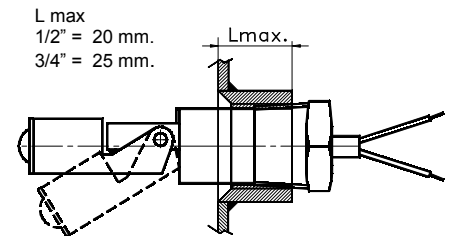
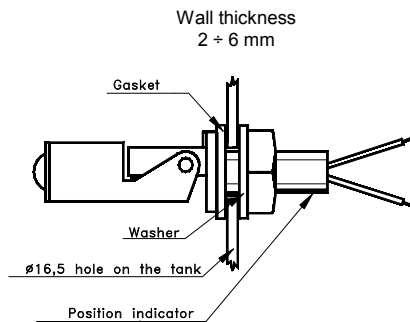
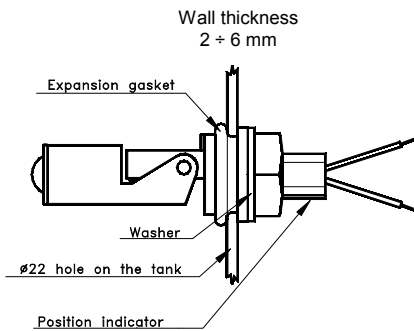

Kit supplied	Compression gasket Washer Fixing nut
---------------------	--

Kit supplied	Flat gasket Washer Fixing nut
---------------------	-------------------------------------

Kit supplied	None
---------------------	------

NOMENCLATURE

S1	FML	3D	20 C	S	C1	-- M	
•							N.1 electrical contact
	•						Tab.1 Type
		•					Tab.3 Electrical contact
			•				Tab.2 Process connection – dimension and type
				•			Tab.2 Sealing gasket material or material for 15-20 version
					•		Tab.3 Wiring
						•	Tab.3 Cable length – only for type C wiring